

60 mm sq. (2.36 inch sq.)

1.8° /step **RoHS**

Unipolar winding, Connector type

Unipolar winding, Lead wire type

Dimensions for attaching NEMA23 are interchangeable (47.14 mm-pitch)

Bipolar winding, Connector type ▶ p. 76

Bipolar winding, Lead wire type

Dimensions for attaching NEMA23 are interchangeable (47.14 mm-pitch) ▶ p. 76

Customizing

Hollow **Shaft modification**

Decelerator **Encoder**

Brake

Varies depending on the model number and quantity. Contact us for details.

Unipolar winding, Connector type

Model number		Holding torque at 2-phase energization [N·m (oz·in) min.]	Rated current A/phase	Wiring resistance Ω /phase	Winding inductance mH/phase	Rotor inertia [$\times 10^{-4}$ kg·m ² (oz·in ²)]	Mass (Weight) [kg (lbs)]	Motor length (L) mm (in)
Single shaft	Dual shaft							
103H7821-0140	103H7821-0110	0.78 (110.5)	1	5.7	8.3	0.275 (1.50)	0.6 (1.32)	44.8 (1.76)
103H7821-0440	103H7821-0410	0.78 (110.5)	2	1.5	2	0.275 (1.50)	0.6 (1.32)	44.8 (1.76)
103H7821-0740	103H7821-0710	0.78 (110.5)	3	0.68	0.8	0.275 (1.50)	0.6 (1.32)	44.8 (1.76)
103H7822-0140	103H7822-0110	1.17 (165.7)	1	6.9	14	0.4 (2.19)	0.77 (1.70)	53.8 (2.12)
103H7822-0440	103H7822-0410	1.17 (165.7)	2	1.8	3.6	0.4 (2.19)	0.77 (1.70)	53.8 (2.12)
103H7822-0740	103H7822-0710	1.17 (165.7)	3	0.8	1.38	0.4 (2.19)	0.77 (1.70)	53.8 (2.12)
103H7823-0140	103H7823-0110	2.1 (297.4)	1	10	21.7	0.84 (4.59)	1.34 (2.95)	85.8 (3.38)
103H7823-0440	103H7823-0410	2.1 (297.4)	2	2.7	5.6	0.84 (4.59)	1.34 (2.95)	85.8 (3.38)
103H7823-0740	103H7823-0710	2.1 (297.4)	3	1.25	2.4	0.84 (4.59)	1.34 (2.95)	85.8 (3.38)

Motor cable: Model No. 4837798-1

Unipolar winding, Lead wire type Dimensions for attaching NEMA23 are interchangeable (47.14 mm-pitch)

Model number		Holding torque at 2-phase energization [N·m (oz·in) min.]	Rated current A/phase	Wiring resistance Ω /phase	Winding inductance mH/phase	Rotor inertia [$\times 10^{-4}$ kg·m ² (oz·in ²)]	Mass (Weight) [kg (lbs)]	Motor length (L) mm (in)
Single shaft	Dual shaft							
103H7821-0160	103H7821-0130	0.78 (110.5)	1	5.7	8.3	0.275 (1.50)	0.6 (1.32)	43.5 (1.71)
103H7821-0460	103H7821-0430	0.78 (110.5)	2	1.5	2	0.275 (1.50)	0.6 (1.32)	43.5 (1.71)
103H7821-0760	103H7821-0730	0.78 (110.5)	3	0.68	0.8	0.275 (1.50)	0.6 (1.32)	43.5 (1.71)
103H7822-0160	103H7822-0130	1.17 (165.7)	1	6.9	14	0.4 (2.19)	0.77 (1.70)	52.5 (2.07)
103H7822-0460	103H7822-0430	1.17 (165.7)	2	1.8	3.6	0.4 (2.19)	0.77 (1.70)	52.5 (2.07)
103H7822-0760	103H7822-0730	1.17 (165.7)	3	0.8	1.38	0.4 (2.19)	0.77 (1.70)	52.5 (2.07)
103H7823-0160	103H7823-0130	2.1 (297.4)	1	10	21.7	0.84 (4.59)	1.34 (2.95)	84.5 (3.33)
103H7823-0460	103H7823-0430	2.1 (297.4)	2	2.7	5.6	0.84 (4.59)	1.34 (2.95)	84.5 (3.33)
103H7823-0760	103H7823-0730	2.1 (297.4)	3	1.25	2.4	0.84 (4.59)	1.34 (2.95)	84.5 (3.33)

Characteristics diagram

103H7821-0140
103H7821-0110

103H7821-0160
103H7821-0130

Constant current circuit
Source voltage: 24 VDC
Operating current:
1 A/phase, 2-phase
energization (full-step)
 $J_L = [0.94 \times 10^{-4} \text{kg} \cdot \text{m}^2 (5.14 \text{oz} \cdot \text{in}^2)]$ use the rubber
coupling]
 f_s : Maximum self-start
frequency when not
loaded

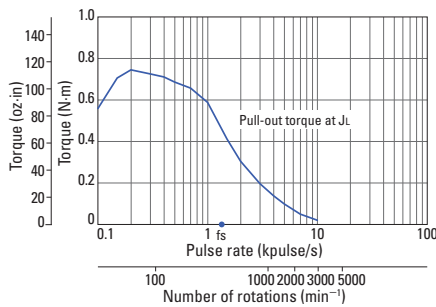

103H7821-0440
103H7821-0410

103H7821-0460
103H7821-0430

Constant current circuit
Source voltage: 24 VDC
Operating current:
2 A/phase, 2-phase
energization (full-step)
 $J_L = [0.94 \times 10^{-4} \text{kg} \cdot \text{m}^2 (5.14 \text{oz} \cdot \text{in}^2)]$ use the rubber
coupling]
 f_s : Maximum self-start
frequency when not
loaded

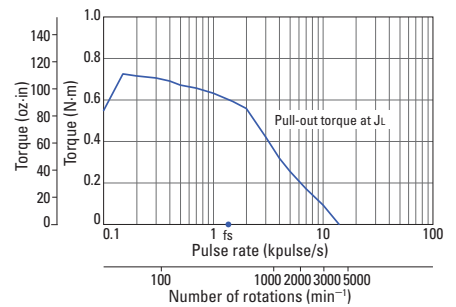

103H7821-0740
103H7821-0710

103H7821-0760
103H7821-0730

Constant current circuit
Source voltage: 24 VDC
Operating current:
3 A/phase, 2-phase
energization (full-step)
 $J_L = [0.94 \times 10^{-4} \text{kg} \cdot \text{m}^2 (5.14 \text{oz} \cdot \text{in}^2)]$ use the rubber
coupling]
 f_s : Maximum self-start
frequency when not
loaded

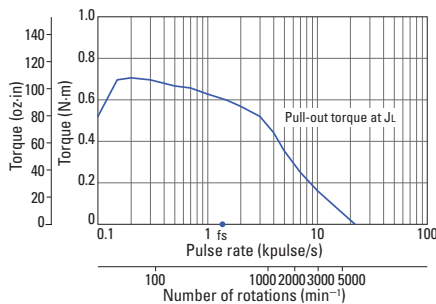

103H7822-0140
103H7822-0110

103H7822-0160
103H7822-0130

Constant current circuit
Source voltage: 24 VDC
Operating current:
1 A/phase, 2-phase
energization (full-step)
 $J_L = [2.6 \times 10^{-4} \text{kg} \cdot \text{m}^2 (14.22 \text{oz} \cdot \text{in}^2)]$ use the rubber
coupling]
 f_s : Maximum self-start
frequency when not
loaded

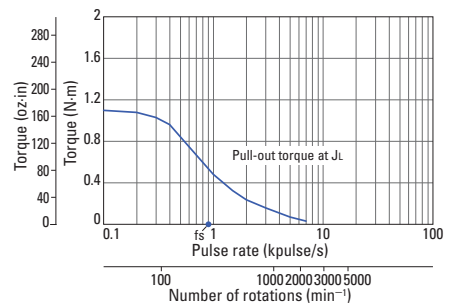

Characteristics diagram

103H7822-0440
103H7822-0410

103H7822-0460
103H7822-0430

Constant current circuit
Source voltage: 24 VDC
Operating current:
2 A/phase, 2-phase
energization (full-step)
 $J_L = [2.6 \times 10^{-4} \text{kg}\cdot\text{m}^2$ (14.22
oz-in²) use the rubber
coupling]
fs: Maximum self-start
frequency when not
loaded

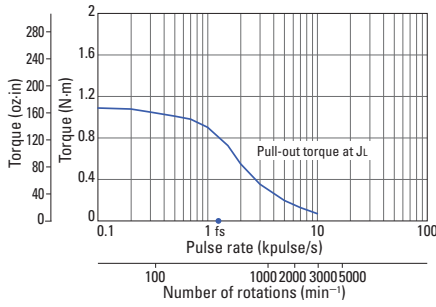

103H7822-0740
103H7822-0710

103H7822-0760
103H7822-0730

Constant current circuit
Source voltage: 24 VDC
Operating current:
3 A/phase, 2-phase
energization (full-step)
 $J_L = [2.6 \times 10^{-4} \text{kg}\cdot\text{m}^2$ (14.22
oz-in²) use the rubber
coupling]
fs: Maximum self-start
frequency when not
loaded

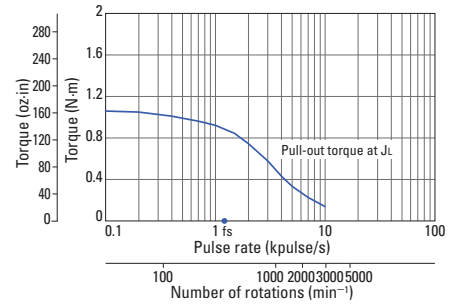

103H7823-0140
103H7823-0110

103H7823-0160
103H7823-0130

Constant current circuit
Source voltage: 24 VDC
Operating current:
1 A/phase, 2-phase
energization (full-step)
 $J_L = [7.4 \times 10^{-4} \text{kg}\cdot\text{m}^2$ (40.46
oz-in²) use the rubber
coupling]
fs: Maximum self-start
frequency when not
loaded

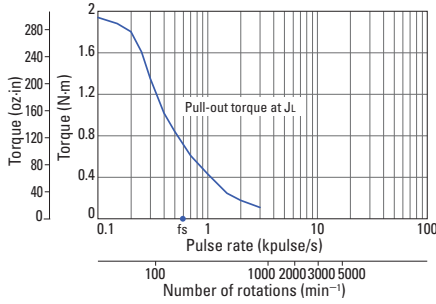

103H7823-0440
103H7823-0410

103H7823-0460
103H7823-0430

Constant current circuit
Source voltage: 24 VDC
Operating current:
2 A/phase, 2-phase
energization (full-step)
 $J_L = [7.4 \times 10^{-4} \text{kg}\cdot\text{m}^2$ (40.46
oz-in²) use the rubber
coupling]
fs: Maximum self-start
frequency when not
loaded

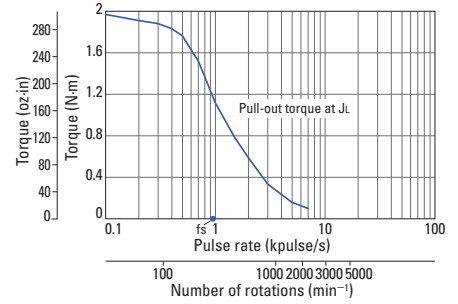

103H7823-0740
103H7823-0710

103H7823-0760
103H7823-0730

Constant current circuit
Source voltage: 24 VDC
Operating current:
3 A/phase, 2-phase
energization (full-step)
 $J_L = [7.4 \times 10^{-4} \text{kg}\cdot\text{m}^2$ (40.46
oz-in²) use the rubber
coupling]
fs: Maximum self-start
frequency when not
loaded

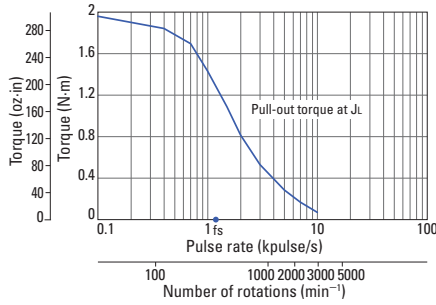

Internal wiring

Connector type

() connector pin number

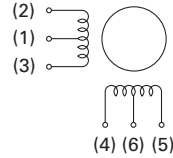

Lead wire type

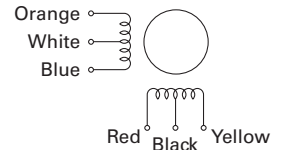

Dimensions [Unit: mm (inch)]

Connector type

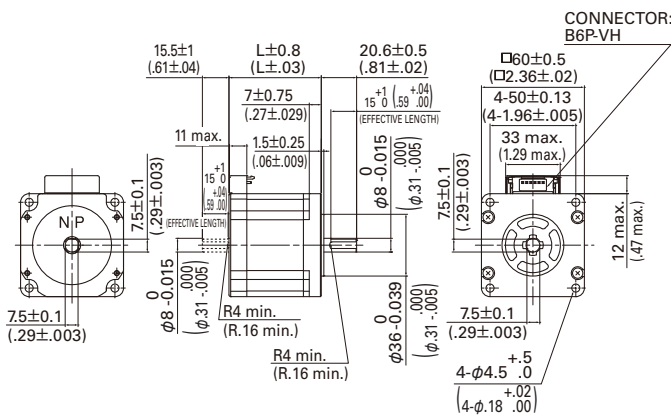

Lead wire type

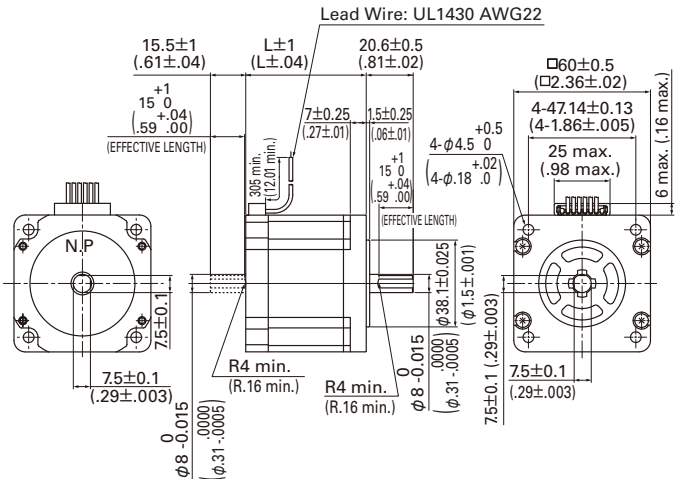

Motor cable Unipolar Model number: 4837798-1

Manufacturer: J.S.T. Mfg. Co., Ltd.
Housing: VHR-6N
Pin: SVH-21T-P1.1

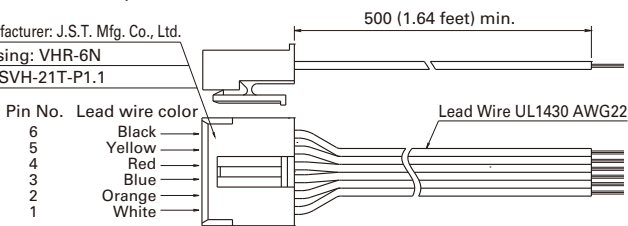

Compatible drivers

- For motor model number 103H782 □ -01 □ 0 (1 A/phase), 103H782 □ -07 □ 0 (3 A/phase)
Driver is not included.

If you require assistance finding a driver, contact us for details.

- For model number 103H782 □ -04 □ 0 (2 A/phase)
Model number: US1D200P10 (DC input)

Operating current select switch setting: 0

The characteristics diagram shown above is from our experimental circuit.

Allowable Radial/Thrust Load

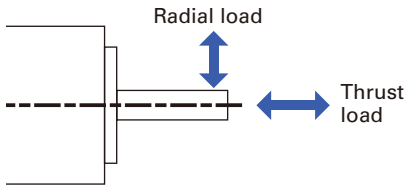

Flange size	Model number	Distance from end of shaft : mm (in)				Thrust load N (lbs)
		0	5	10	15	
Radial load : N (lbs)						
14 mm sq. (0.55 in sq.)	SH2141	10 (2.25)	11 (2.47)	13 (2.92)	-	0.7 (0.16)
28 mm sq. (1.10 in sq.)	SH228 □	42 (9)	48 (10)	56 (12)	66 (14)	3 (0.67)
35 mm sq. (1.38 in sq.)	SH353 □	40 (8)	50 (11)	67 (15)	98 (22)	10 (2.25)
42 mm sq. (1.65 in sq.)	103H52 □□ SH142 □	22 (4)	26 (5)	33 (7)	46 (10)	10 (2.25)
50 mm sq. (1.97 in sq.)	103H670 □	71 (15)	87 (19)	115 (25)	167 (37)	15 (3.37)
56 mm sq. (2.20 in sq.)	103H712 □	52 (11)	65 (14)	85 (19)	123 (27)	15 (3.37)
	103H7128	85 (19)	105 (23)	138 (31)	200 (44)	15 (3.37)
60 mm sq. (2.36 in sq.)	103H782 □	70 (15)	87 (19)	114 (25)	165 (37)	20 (4.50)
	SH160 □					15 (3.37)
86 mm sq. (3.39 in sq.)	SM286 □ SH286 □	167 (37)	193 (43)	229 (51)	280 (62)	60 (13.488)
	103H822 □					191 (43)
φ 106 mm (φ 4.17 in)	103H8922 □	321 (72)	356 (79)	401 (90)	457 (101)	100 (22.48)

Internal Wiring and Rotation Direction

Unipolar winding

Connector type Model number: 103H52 □□

Internal wire connection

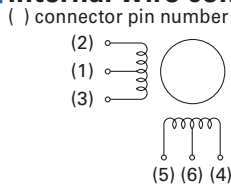

Connector type Model number: 103H782 □□

Internal wire connection

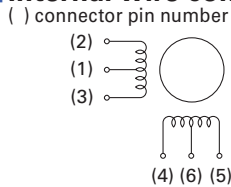

Lead wire type

Internal wire connection

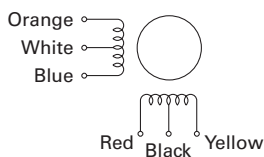

Direction of motor rotation

When excited by a direct current in the order shown below, the direction of rotation is clockwise as viewed from the output shaft side.

Exciting order	Connector pin number				
	(1.6)	(5)	(3)	(4)	(2)
1	+	-	-	-	-
2	+	-	-	-	-
3	+	-	-	-	-
4	+	-	-	-	-

Direction of motor rotation

When excited by a direct current in the order shown below, the direction of rotation is clockwise as viewed from the output shaft side.

Exciting order	Connector pin number				
	(1.6)	(4)	(3)	(5)	(2)
1	+	-	-	-	-
2	+	-	-	-	-
3	+	-	-	-	-
4	+	-	-	-	-

Direction of motor rotation

When excited by a direct current in the order shown below, the direction of rotation is clockwise as viewed from the output shaft side.

Exciting order	Lead wire color				
	White & black	Red	Blue	Yellow	Orange
1	+	-	-	-	-
2	+	-	-	-	-
3	+	-	-	-	-
4	+	-	-	-	-

Bipolar winding

Connector type

Internal wire connection

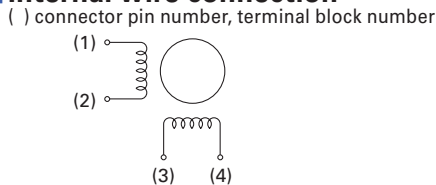

Lead wire type

Internal wire connection

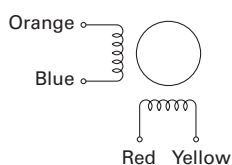

Direction of motor rotation

When excited by a direct current in the order shown below, the direction of rotation is clockwise as viewed from the output shaft side.

Exciting order	Connector pin number, terminal block number			
	(3)	(2)	(4)	(1)
1	-	-	+	+
2	+	-	-	+
3	+	+	-	-
4	-	+	+	-

Direction of motor rotation

When excited by a direct current in the order shown below, the direction of rotation is clockwise as viewed from the output shaft side.

Exciting order	Lead wire color			
	Red	Blue	Yellow	Orange
1	-	-	+	+
2	+	-	-	+
3	+	+	-	-
4	-	+	+	-

AC Input Set Models/
Drivers

DC Input Set Models/
Drivers

Stepping Motors

IP65 Splash and Dust
Proof Stepping Motors

Stepping Motors for
Vacuum Environments

Synchronous Motors

Stepping Motors with
Integrated Drivers

General Specifications

Motor model number	SH2141	SH228 □	SH353 □	SS242 □	SH142 □	103H52 □□	SS250 □	103H67 □□	103H712 □
Type	-								
Operating ambient temperature	- 10°C to + 50°C								
Conversation temperature	- 20°C to + 65°C								
Operating ambient humidity	20 to 90% RH (no condensation)								
Conversation humidity	5 to 95% RH (no condensation)								
Operation altitude	1000 m (3281 feet) max. above sea level								
Vibration resistance	Vibration frequency 10 to 500 Hz, total amplitude 1.52 mm (10 to 70 Hz), vibration acceleration 150 m/s ² (70 to 500 Hz), sweep time 15 min/cycle, 12 sweeps in each X, Y and Z direction.								
Impact resistance	500 m/s ² of acceleration for 11 ms with half-sine wave applying three times for X, Y, and Z axes each, 18 times in total.								
Insulation class	Class B (+130°C)								
Withstandable voltage	At normal temperature and humidity, no failure with 500 VAC @50/60 Hz applied for one minute between motor winding and frame.							At normal temperature and humidity, no failure with 1000 VAC @50/60 Hz applied for one minute between motor winding and frame.	
Insulation resistance	At normal temperature and humidity, not less than 100 MΩ between winding and frame by 500 VDC megger.								
Protection grade	IP40								
Winding temperature rise	80 K max. (Based on Sanyo Denki standard)								
Static angle error	± 0.09°				± 0.054°		± 0.09°		
Thrust play *1	0.075 mm (0.003 in) max. (load: 0.35 N (0.08 lbs))	0.075 mm (0.003 in) max. (load: 1.5 N (0.34 lbs))	0.075 mm (0.003 in) max. (load: 5 N (1.12 lbs))	0.075 mm (0.003 in) max. (load: 4 N (0.9 lbs))	0.075 mm (0.003 in) max. (load: 5 N (1.12 lbs))	0.075 mm (0.003 in) max. (load: 5 N (1.12 lbs))	0.075 mm (0.003 in) max. (load: 4 N (0.9 lbs))	0.075 mm (0.003 in) max. (load: 10 N (2.25 lbs))	0.075 mm (0.003 in) max. (load: 10 N (2.25 lbs))
Radial play *2	0.025 mm (0.001 in) max. (load: 5 N (1.12 lbs))								
Shaft runout	0.025 mm (0.001 in)								
Concentricity of mounting pilot relative to shaft	φ 0.05 mm (φ 0.002 in)	φ 0.05 mm (φ 0.002 in)	φ 0.075 mm (φ 0.003 in)	φ 0.075 mm (φ 0.003 in)	φ 0.05 mm (φ 0.002 in)	φ 0.05 mm (φ 0.002 in)	φ 0.075 mm (φ 0.003 in)	φ 0.075 mm (φ 0.003 in)	φ 0.075 mm (φ 0.003 in)
Squareness of mounting surface relative to shaft	0.1 mm (0.004 in)	0.1 mm (0.004 in)	0.1 mm (0.004 in)	0.1 mm (0.004 in)	0.1 mm (0.004 in)	0.1 mm (0.004 in)	0.1 mm (0.004 in)	0.1 mm (0.004 in)	0.1 mm (0.004 in)
Direction of motor mounting	Can be freely mounted vertically or horizontally								

Motor model number	SH160 □	103H78 □□	SH286 □	103H8922 □	SM286 □	103H712 □ -6 □□ 0 CE Model	103H822 □ -6 □□ 0 CE Model	103H8922 □ -63 □ 1 CE Model	
Type	-				S1 (continuous operation)				
Operating ambient temperature	- 10°C to + 50°C				- 10°C to + 40°C				
Conversation temperature	- 20°C to + 65°C				- 20°C to + 60°C				
Operating ambient humidity	20 to 90% RH (no condensation)				95% max.: 40°C max., 57% max.: 50°C max., 35% max.: 60°C max. (no condensation)				
Conversation humidity	5 to 95% RH (no condensation)								
Operation altitude	1000 m (3280 feet) max. above sea level								
Vibration resistance	Vibration frequency 10 to 500 Hz, total amplitude 1.52 mm (10 to 70 Hz), vibration acceleration 150 m/s ² (70 to 500 Hz), sweep time 15 min/cycle, 12 sweeps in each X, Y and Z direction.								
Impact resistance	500 m/s ² of acceleration for 11 ms with half-sine wave applying three times for X, Y and Z axes each, 18 times in total.								
Insulation class	Class B (+130°C)				Class F (+155°C)		Class B (+130°C)		
Withstandable voltage	At normal temperature and humidity, no failure with 1000 VAC @50/60 Hz applied for one minute between motor winding and frame.				At normal temperature and humidity, no failure with 1500 VAC @50/60 Hz applied for one minute between motor winding and frame.				
Insulation resistance	At normal temperature and humidity, not less than 100 MΩ between winding and frame by 500 VDC megger.								
Protection grade	IP40				IP43				
Winding temperature rise	80 K max. (Based on Sanyo Denki standard)								
Static angle error	± 0.054°		± 0.09°						
Thrust play *1	0.075 mm (0.003 in) max. (load: 10 N (2.25 lbs))								
Radial play *2	0.025 mm (0.001 in) (load: 5 N (1.12 lbs))	0.025 mm (0.001 in) (load: 5 N (1.12 lbs))	0.025 mm (0.001 in) (load: 5 N (1.12 lbs))	0.025 mm (0.001 in) (load: 10 N (2.25 lbs))	0.025 mm (0.001 in) (load: 5 N (1.12 lbs))	0.025 mm (0.001 in) (load: 5 N (1.12 lbs))	0.025 mm (0.001 in) (load: 5 N (1.12 lbs))	0.025 mm (0.001 in) (load: 10 N (2.25 lbs))	
Shaft runout	0.025 mm (0.001 in)								
Concentricity of mounting pilot relative to shaft	φ 0.075 mm (φ 0.003 in)								
Squareness of mounting surface relative to shaft	0.1 mm (0.004 in)	0.075 mm (0.003 in)	0.15 mm (0.006 in)	0.1 mm (0.004 in)	0.15 mm (0.006 in)	0.075 mm (0.003 in)	0.1 mm (0.004 in)	0.1 mm (0.004 in)	
Direction of motor mounting	Can be freely mounted vertically or horizontally								

*1 Thrust play: Shaft displacement under axial load.

*2 Radial play: Shaft displacement under radial load applied 1/3rd of the length from the end of the shaft.

Safety standards

Model Number: **SM286** □ CE/UL marked models

CE (TÜV)	Standard category	Applicable standard	
	Low-voltage directives	EN60034-1, EN60034-5	
UL	Acquired standards	Applicable standard	File No.
	UL	UL1004-1, UL1004-6	E179832
	UL for Canada	CSA C22.2 No.100	

Model Number: **103H712** □ -6 □□ 0, **103H822** □ -6 □□ 0, **103H8922** □ -63 □ 1 CE marked model

CE (TÜV)	Standard category	Applicable standard	
	Low-voltage directives	EN60034-1, EN60034-5	

